

Pin Definitions

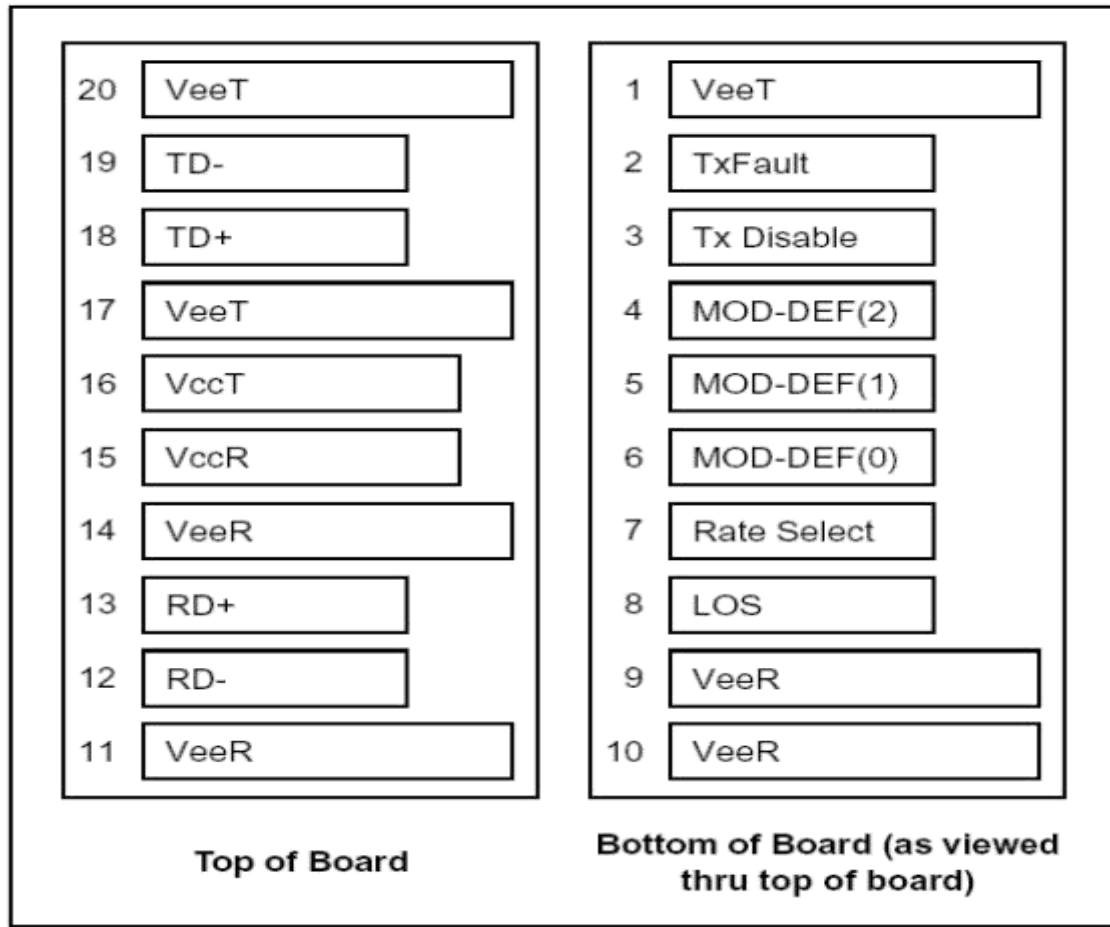

Figure 1. Pin Definitions

Pin Descriptions

PIN	NAME	FUNCTION	SEQ.	NOTES
1	VeeT	Transmitter Ground	1	VeeT and VeeR are connected in SFP.
2	TX_FAULT	Transmitter Fault Indication	3	Not Implemented. Tied to VeeT in SFP.
3	TX_DISABLE	Transmitter Disable	3	See TX Disable.
4	MOD DEF (2)	Module Definition 2	3	Data Line for Serial ID and Bidirectional Data Transfer bus.
5	MOD DEF (1)	Module Definition 1	3	Clock Line for Serial ID and Bidirectional Data Transfer bus.
6	MOD DEF (0)	Module Definition 0	3	Tied to Vee in SFP.
7	RATE SELECT	Not Implemented	3	Not implemented. 33K pulldown to Vee in SFP.

8	LOS	Loss of Signal	3	See LOS option.
9	VeeR	Receiver Ground	1	VeeT and VeeR are connected in SFP.
10	VeeR	Receiver Ground	1	VeeT and VeeR are connected in SFP.
11	VeeR	Receiver Ground	1	VeeT and VeeR are connected in SFP.
12	RD-	Inverted Received Data out	3	AC coupled 100 ohm differential high speed data lines.
13	RD+	Non-Inverted Received Data out	3	AC coupled 100 ohm differential high speed data lines.
14	VeeR	Receiver Ground	1	VeeT and VeeR are connected in SFP.
15	VccR	Receiver Power	2	VccR and VccT are connected in SFP.
16	VccT	Transmitter Power	2	VccR and VccT are connected in SFP.
17	VeeT	Transmitter Ground	1	VeeT and VeeR are connected in SFP.
18	TD+	Non-inverted Data In	3	AC coupled 100 ohm differential high speed data lines.
19	TD-	Inverted Data In	3	AC coupled 100 ohm differential high speed data lines.
20	VeeT	Transmitter Ground	1	VeeT and VeeR are connected in SFP.

Notes:

Plug Seq.: Pin engagement sequence during hot plugging.

1) TX Fault is not supported and is always connected to ground.

2) TX disable, an input used to reset the transceiver module, This pin is pulled up within the module with a 4.7 KΩ resistor.

Low (0 – 0.8 V): Transceiver on Between (0.8 V and 2.0 V): Undefined

High (2.0 – 3.465 V): Transceiver in reset state

Open: Transceiver in reset state

3) Mod-Def 0,1,2. These are the module definition pins. They should be pulled up with a 4.7K~10K resistor on the host board.

The pull-up voltage shall be VccT or VccR

Mod-Def 0 is grounded by the module to indicate that the module is present

Mod-Def 1 is the clock line of two wire serial interface for serial ID

Mod-Def 2 is the data line of two wire serial interface for serial ID

4) RX_LOS (Loss of Signal): LVTTTL compatible with a maximum voltage of Host_Vcc. RX_LOS can enabled or disabled (Refer to Ordering information),RX_LOS is not used and is always tied to ground via 100-ohm resistor.

5) RD-/+ : These are the differential receiver outputs. They are AC coupled 100 differential lines which should be terminated with 100 (differential) at the user SERDES.

6) TD-/+ : These are the differential transmitter inputs. They are AC-coupled, differential lines with 100 differential termination inside the module.

+3.3V Volt Electrical Power Interface

Parameter	Symbol	Min	Typ	Max	Units	Notes/Conditions
Supply Current	I _s		320	375	mA	1.2W max power over full range of voltage and temperature. See caution note below
Input Voltage	V _{cc}	3.13	3.3	3.47	V	Referenced to GND
Maximum Voltage	V _{max}			4	V	Maximum

Low-speed signals, electronic characteristics

Parameter	Symbol	Min	Max	Units	Notes/Conditions
SFP Output LOW	VOL	0	0.5	V	4.7k to 10k pull-up to host_Vcc, measured at host side of connector
SFP Output HIGH	VOH	host_Vcc - 0.5	host_Vcc + 0.3	V	4.7k to 10k pull-up to host_Vcc, measured at host side of connector
SFP Input LOW	VIL	0	0.8	V	4.7k to 10k pull-up to Vcc, measured at SFP side of connector
SFP Input HIGH	VIH	2	Vcc + 0.3	V	4.7k to 10k pull-up to Vcc, measured at SFP side of connector

High-speed electrical interface, transmission line-SFP

Parameter	Symbol	Min	Typ	Max	Units	Notes/Conditions
Line Frequency	f _L		125		MHz	5-level encoding, per IEEE 802.3
Tx Output Impedance	Z _{out,TX}		100		Ohm	Differential, for all Frequencies between 1MHz and 125MHz
Rx Input Impedance	Z _{in,RX}		100		Ohm	Differential, for all Frequencies between 1MHz and 125MHz

High-speed electrical interface, host-SFP

Parameter	Symbol	Min	Typ	Max	Units	Notes/Conditions
Single ended data input swing	Vinswing	250		1200	mV	Single ended
Single ended data output swing	Voutswing	350		800	mV	Single ended
Rise/Fall Time	Tr, Tf		175		psec	20%-80%
Tx Input Impedance	Zin		50		Ohm	Single ended
Rx Output Impedance	Zout		50		Ohm	Single ended

General specifications

Parameter	Symbol	Min	Typical	Max	Unit
Operating Case Temperature	Commercial	Tc	0	70	°C
	Extend		-20	85	°C
Storage Temperature			-40	85	°C

Mechanical Specifications

The host-side of the ES-T1-R conforms to the mechanical specifications outlined in the SFP MSA1.

The front portion of the SFP (part extending beyond the face plate of the host) is larger to accommodate the RJ-45 connector

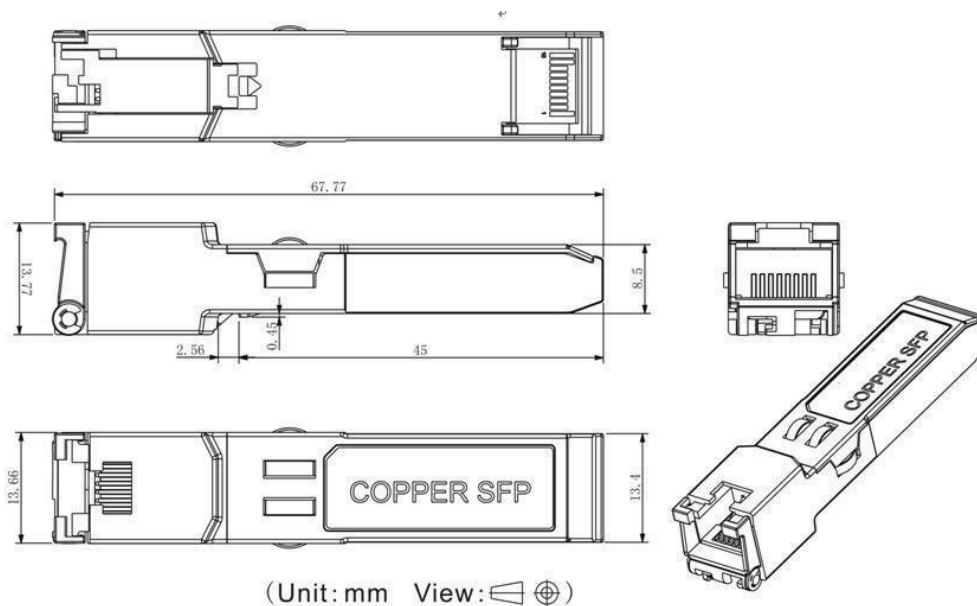

References

1. Small Form Factor Pluggable (SFP) Transceiver Multi-Source Agreement (MSA), September 2000.
2. IEEE802.3 – 2002.
3. “AT24C01A/02/04/08/16 2-Wire Serial CMOS E2PROM”, Atmel Corporation.

Regulatory Compliance

Feature	Reference	Performance
Electrostatic discharge (ESD)	IEC/EN 61000-4-2	Compatible with standards
Electromagnetic Interference (EMI)	FCC Part 15 Class B EN 55022 Class B (CISPR 22A)	Compatible with standards
Laser Eye Safety	FDA 21CFR 1040.10, 1040.11 IEC/EN 60825-1, 2	Class 1 laser product
Component Recognition	IEC/EN 60950, UL	Compatible with standards
ROHS	2002/95/EC	Compatible with standards
EMC	EN61000-3	Compatible with standards

Ordering information

Part number	Speed mode	MAC interface	TX Disable function	Link Indicator on RX_LOS Pin	Temp
ES-T1-R	1000Mbps	SERDES	Yes	Yes	0~70°C
ES-T2-R	10/100/1000Mbps	SGMII	Yes	Yes	0~70°C
ES-T3-R	10/100M	SGMII	Yes	Yes	0~70°C
ES-T4-R	1000M	SERDES	Yes	Yes	-20°C~+85°C
ES-T6-R	10/100/1000Mbps	SGMII	Yes	Yes	-20°C~+85°C